

DETC2014-35096

DESIGN OF A COMPACT, LIGHTWEIGHT, ELECTROMECHANICAL LINEAR SERIES ELASTIC ACTUATOR

Coleman Knabe
Virginia Tech
Blacksburg, Virginia, USA

Bryce Lee
Virginia Tech
Blacksburg, Virginia, USA

Viktor Orekhov
Virginia Tech
Blacksburg, Virginia, USA

Dennis Hong, Ph.D.
University of California Los Angeles
Los Angeles, California, USA

ABSTRACT

Series Elastic Actuators (SEAs) have several benefits for force controlled robotic applications. Typical SEAs place an elastic element between the motor and the load, increasing shock tolerance, allowing for more accurate and stable force control, and creating the potential for energy storage. This paper presents the design of a compact, lightweight, low-friction, electromechanical linear SEA used in the lower body of the Tactical Hazardous Operations Robot (THOR). The THOR SEA is an evolutionary improvement upon the SAFFiR SEA [1]. Design changes focused on reducing the size and fixed length of the actuator while increasing its load capacity. This SEA pairs a ball screw-driven linear actuator with a configurable elastic member. The elastic element is a titanium leaf spring with a removable pivot, setting the compliance to either 650 or 372 [kN/m]. The compliant beam is positioned parallel to the actuator, reducing overall packaging size by relocating the space required for spring deflection. Unlike typical SEAs which measure force through spring deflection, the force applied to the titanium beam is measured through a tension/compression load cell located in line with each actuator, resulting in a measurable load range of +/-2225 [N] at a tolerance of +/-1 [N]. A pair of universal joints connects the actuator to the compliant beam and to the robot frame. As the size of each universal joint is greatly dependent upon its required range of motion, each joint design is tailored to fit a particular angle range to further reduce packaging size. Potential research topics involving the actuator are proposed for future work.

1. INTRODUCTION

Series elastic actuators (SEAs) have several benefits for force controlled robotic applications, including high bandwidth force control, energy storage, and impact absorption [2-7]. Several humanoid robotic platforms use linear SEAs for those benefits, and because they mimic the biomechanical structure of legged animals [2,4,8-11]. Linear actuators can be placed close to skeletal bodies while positioning the majority of their mass and volume away from the joint itself.

The original SEAs were designed around ball screw drives with coil springs to provide the elastic element [2-7]. These SEAs are self-contained packages that are well designed for high bandwidth force control. By building around an efficient ball screw, the overall friction in the system is decreased. This allows the actuator to command small forces without the interference of Coulomb friction. The SAFFiR linear SEA is designed around a ball screw, but its configurable compliant spring is isolated from the linear actuator [1]. This packaging allows for the redesign of either subsystem without impacting the other. There are also linear actuators centered around lead screws [12,13]. These actuators have more friction in the system, but are lower in cost and lighter weight. Depending on the application, this may be a more important design consideration.

Series elasticity plays a large role in determining the effectiveness of an SEA. Low-elasticity systems are easier to control, but have worse force control performance. High-elasticity systems are the opposite, with better performance capabilities and more difficult control. A few groups have designed compliant mechanisms that have a range of stiffnesses [14-16]. These mechanisms allow the user to alter the performance of their SEA without manufacturing a new system.

Parallel actuation enables multiple actuators to control the same number of degrees of freedom in a joint. Several legged robotic platforms use parallel SEAs to drive their hip and ankle joints [8,9,11]. This actuator configuration moves mass higher up each link, decreasing the overall inertia of the leg. Additionally, two actuators cooperatively pushing on a joint can increase its torque potential compared to each actuator driving its own joint.

The lower body of the Tactical Hazardous Operations Robot (THOR), seen in Figure 1, uses twelve linear SEAs [9]. THOR features three similar versions of the SEA: two driving each ankle joint through a carbon fiber tube, two for the knee and hip pitch joints driven by a mechanical linkage connected to the output of the ball screw, and a more compact carbon fiber version for the hip yaw and roll joints [9,17]. The actuators spanning the hip and ankle joints are in a parallel configuration. Similar to the SAFFiR SEA design, the configurable compliant spring is independent of the actuator. The actuators attach through custom universal joints to the structure of THOR and to the compliant members.



Figure 1: Tactical Hazardous Operations Robot (THOR)

This paper details the design of the THOR SEA, and its relation to providing a high-force actuator within a small packaging space. Section 2 details the key actuator subsystems which underwent design changes to meet packaging and load requirements. Section 3 describes the design of the custom universal joints employed at each end of the actuators. Section 4 briefly discusses an alternate use of the linear SEA for THOR. Section 5 summarizes and concludes this paper, including recommendations for future research using this SEA.

2. SERIES ELASTIC ACTUATOR DESIGN

The actuators designed for THOR are an evolutionary improvement upon the SAFFiR SEAs [1]. The fundamental

concept of pairing a titanium spring with an electric motor-driven ball screw actuator remains the same. However, several redefined parts and key reconfigurations drastically improve the performance over the previous SEA. The belt transmission and bearing housing were redesigned to be more compact. Using the same 100 [W] Maxon EC4-pole-30 motors with a larger 3:1 pulley ratio and a 2.0 [mm] pitch precision ground ball screw, the peak force has been increased from 1,000 [N] to 2,225 [N] and the continuous force doubled from 300 [N] to 600 [N]. Another design change was to reduce the size of each universal joint, creating a smaller package which achieves a specific angle range. A rendering of the THOR SEA used on the hip roll/yaw joint is shown in Figure 2. A comparison of the THOR and SAFFiR hip SEAs can be found in Table 1.

One important measure of the actuator is its fixed length. The fixed length is defined as the length of an actuator with zero-stroke; or the minimum length minus its stroke, accounting for all the components that are integral to the actuator's function. A shorter fixed length is beneficial for package the actuator in the robot body, especially at joints using parallel actuation.

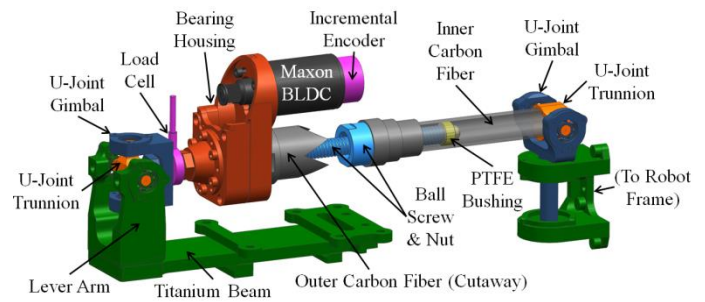

Figure 2: Rendering of the THOR hip SEA

Table 1: Comparison of the hip SEAs for SAFFiR and THOR

SEA Characteristic	SAFFiR	THOR
Weight (Actuator Only) [kg]	0.653	0.726
Weight (Full SEA) [kg]	0.816	0.938
Maximum Speed [m/s]	0.35	0.19
Stroke [m]	0.110	0.085
Fixed Length [m]	0.153	0.111
Continuous Force [N]	300	600
Maximum Force [N]	1,000	2,225
Spring Constant [kN/m]	145– 512	372 or 650
Ball Screw Lead [mm]	3.175	2.0

The THOR linear actuator has the same functional elements as the SAFFiR actuator. A ball screw is positioned at the center of the assembly and is connected to the motor through a timing belt pulley. The housing contains compact sets of radial and thrust bearings sandwiched around the drive pulley to transmit the forces from the ball screw to the housing. A carbon fiber tube transmits the forces from the ball nut to the universal joint at the bottom of the actuator. The universal joints on both ends of the actuator ensure it is loaded as a two-force member and connect the actuator back to the structure of

THOR. Similar to the SAFFiR actuator, the THOR actuator incorporates a uni-directional load cell for force sensing. Furthermore, there is no linear guide to restrict rotation of the ball nut, as the universal joints constrain this rotation instead. An absolute optical encoder is located at each joint to compensate for the potentially detrimental effects of cantilever deflection on force control. The design changes of the THOR SEA will be highlighted in this section.

2.1 Motor Housing

The subassembly with the greatest potential for size reduction was the bearing housing, shown in Figure 3. Much of its design was consequent on the bearings chosen. The largest bearing that the selected ball screw could support was a 7 [mm] bore: a non-standard size which greatly reduced bearing availability. A design was chosen that sandwiches the drive pulley between two pairs of bearings to reduce the moment load on each bearing and to provide double support for the ball screw. While angular contact bearings can support a greater axial load than other radial bearings, none were available with a 7 [mm] bore than could support a 2,225 [N] axial load. Instead, the THOR actuator utilizes a pair of thrust roller bearings to support the axial load, and a pair of deep groove bearings to support any radial tipping loads.

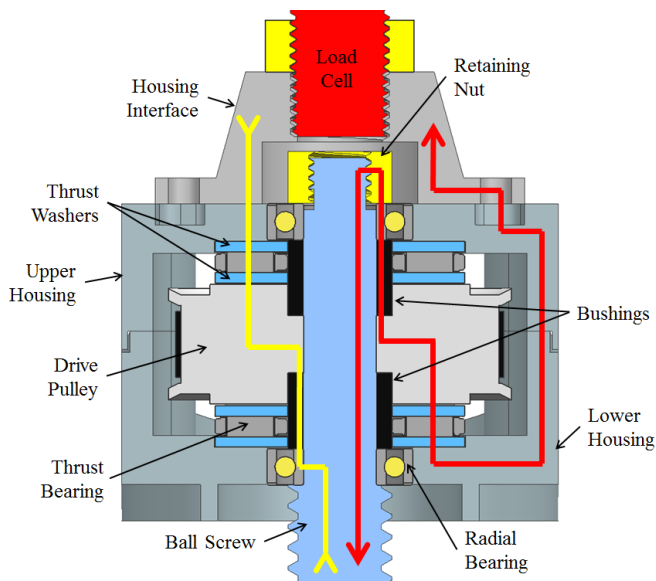

Figure 3: Cutaway view of bearing housing, showing the compression and tension load paths. Each load path is symmetrical

The compression load path, shown in yellow in Figure 3, travels from the ball screw, to the inner race of the radial bearing, to the first bushing, to the pulley, to the upper thrust bearing, and into the upper housing to the load cell. The tension load path, shown in red in Figure 3, is a bit more involved: the load path travels up the ball screw, pulling down on the nut, to the inner race of the radial bearing, to the bushing and the pulley, through the thrust bearing to the lower housing. The

load then transfers to the upper housing through bolts, then to the load cell. It is important to note that in neither case does the load transfer from the inner race of the radial bearings to the outer race; doing so would destroy the bearings at high load.

The drive pulley is secured to the shaft using bushings press fit into the pulley counterbore. The bushings rest against the inner race of radial bearings, which are tightened between the ball screw and the retaining nut. To restrict pulley slip, a torque wrench is used to tighten the nut to 1.2 [Nm], which is over three times the peak commandable motor torque. The radial bearings are slip fit into the upper and lower housings to ensure they support no axial loads consequent of any backlash within the housing. The thrust bearings contact the face of the pulley and are preloaded against the upper and lower housings using shims.

The resulting housing constrains the pulley and eliminates axial and radial play within a smaller package than present on the SAFFiR SEA. Furthermore, it provides an interface to the upper universal joint, aligns and fastens the protective outer carbon fiber tube, and contains the belt tensioning motor mount shown in Figure 4.

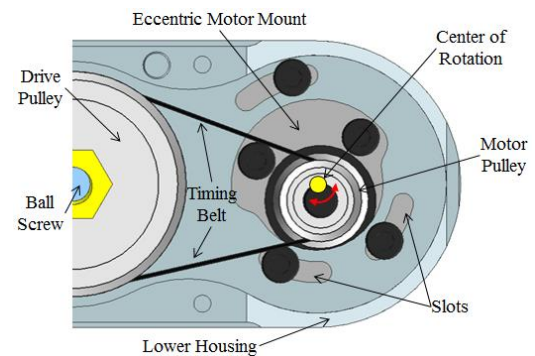

Figure 4: Eccentric motor mount for belt tensioning (top view of bearing housing)

The motor fits eccentrically underneath the mounting plate, which is secured to the actuator housing through the three outer bolts. Rotating the motor clockwise towards the ball screw allows for the belt to slip over the motor pulley, while rotating counterclockwise away from the ball screw applies appropriate belt tension. This is a significant improvement over the SAFFiR actuator since it is easy for one person to adjust belt tension, and it provides a more rigid structure for both the motor mount and the lower actuator housing. Additionally, the slots are spaced so that there is always a belt that will fit tensioned in this assembly, regardless of the pulley ratio. Due to extremely tight packaging constraints in the robot, there is a mirrored version of the actuator housing which relocated motor to avoid interferences.

At the top of the housing is the integrated uni-directional load cell. The Futek LCM200 is bolted directly into the housing, not into the universal joint cross gimbal like the SAFFiR SEA. Though this design increases the overall length of the actuator, it keeps the load cell aligned with the actuator at

all times. Bending loads can distort the load cell measurements and eventually damage or destroy the sensor. This design greatly reduces the bending loads placed through the load cell.

Furthermore, the angle of the housing relative to the upper universal joint needed to be set accurately to meet packaging requirements. The orientation of each motor housing in the body of THOR needed to be assembled accurately to prevent physical interferences with the body structure over the full joint ranges of motion. This was accomplished through the use of a jig during attachment of the load cell to the housing interface. The jig accommodates angles at 5° increments, allowing the length of the interface to be constant within 0.1 [mm] for any housing angle.

2.2 Configurable Compliant Spring Design

The elastic element is what delineates a rigid actuator from an SEA. Typical linear SEAs place a linear spring between either the motor and load or the motor and ground. Similar to its counterpart on SAFFiR, the THOR configurable compliant spring is an independent cantilevered titanium leaf spring [14]. The spring on SAFFiR is placed perpendicular to the main axis of the actuator, allowing the actuator to directly push on the beam. On THOR, the configurable compliant spring is located parallel to the main axis of the actuator. The two are connected through a rigid aluminum lever arm that also serves as part of the universal joint. An image of this connection can be seen in Figure 5.

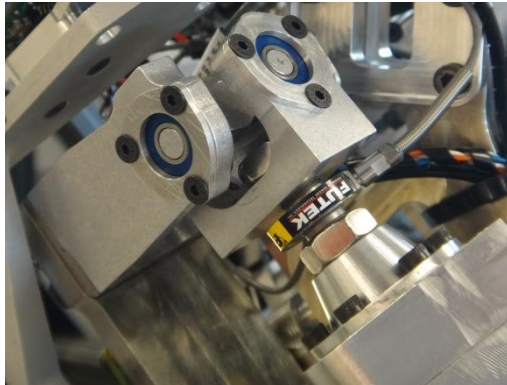

Figure 5: Actuator attachment to the configurable compliant spring

Not only does this parallel configuration relocate the space required for spring deflection, it takes advantage of load properties to reduce the size of the cantilever to achieve the same spring stiffness. The beam is loaded in nearly perfect moment loading through the lever arm. This arrangement allows for increased energy storage throughout the length of the beam compared to an identically sized cantilever loaded by a concentrated point load, such as with the SAFFiR SEA. This configuration is essential to supporting the larger actuator forces present on THOR.

Using the loading properties of a cantilever in pure bending, the spring dimensions were chosen as 6.5 [mm] by

38.0 [mm] with a configurable length. A removable pivot, shown in blue in Figure 6, allows for selection of a more stiff 650 [kN/m] or a more compliant 372 [kN/m] spring stiffness rate. In addition, a lockout can be mounted to the spring lever arm, preventing spring deflection. The lockout piece is tapered to prevent any hysteresis during its installation.

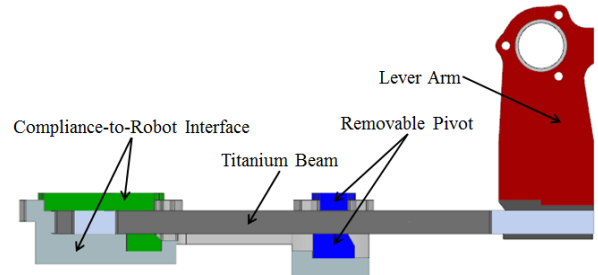

Figure 6: Cutaway view of the configurable compliant member. The blue pivots are removable to change the stiffness of the spring

Each compliant spring uses the same interface to attach to the structure of THOR. This universal interface expedited the design process and simplified the manufacture. In addition to the identical structural interfaces, each lever arm connecting the compliant beam to the actuator is the same.

3. UNIVERSAL JOINT DESIGNS

Another portion of the actuator that has a profound effect on the fixed length, the universal joints at each end of the actuator, serve to attach the actuator to the robot frame and constrain the actuator as an axial tension/compression two-force member. The parallel actuation configuration on THOR would not be possible without the use of universal joints at each end of the SEA. The packaging size of the universal joint is highly dependent on the required operating angles of its axes. THOR uses a variety of universal joints, shown in Figure 7, each with varying lengths and configurations suitable for their operating angle ranges.

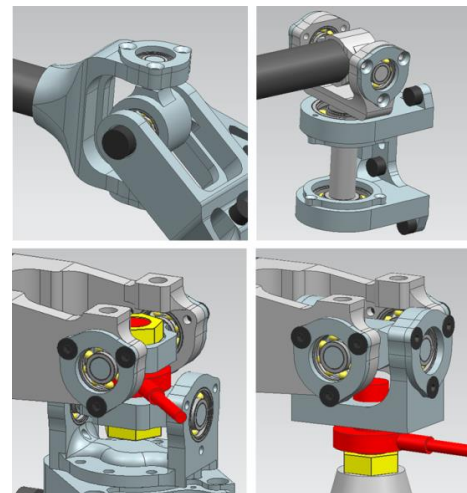

Figure 7: Universal joint designs. From upper left to lower right: lower ankle, lower hip, knee, universal upper

The universal joint design occurred simultaneously with the actuator end placement because each impacted the other. Moving the actuator ends modified the required universal joint range of motion, which, in turn, changed the attainable fixed length of the actuator. Using the final kinematic arrangement of the THOR actuators, the final range of motion of the roll and pitch axes for each universal joint was determined over its respective joint space.

3.1 Upper Universal Joint

The upper universal joint connects the housing of the actuator to the compliant spring. In an effort to reduce the number of unique parts, a single upper universal joint, shown in Figure 5, was created which satisfies the angle requirements for each actuator location. The angle requirements collected in Table 2 were chosen from the minimum and maximum pitch-roll pair present at the corners of the joint space. The upper universal joint follows a traditional universal joint configuration using two gimbals connected by a trunnion with two orthogonal intersecting axes. The pitch axis is defined as the axis of the universal joint attached to the robot structure, and the roll axis is attached to the actuator. Because of the symmetry of THOR, the roll measurement that drove the universal joint design is the larger in magnitude of the minimum and maximum.

Table 2: Upper universal joint range of motion requirements

Universal Joint Location	Min. Roll	Max. Roll	Min. Pitch	Max. Pitch
Front Hip	-3.0	12.6	-7.3	6.4
Back Hip	-4.9	3.7	-14.8	4.0
Ankle	-1.9	3.2	-8.1	2.3
Overall	-4.9	12.6	-14.8	6.4

Interferences between the input and output gimbal are dependent on the operating angle of the universal joint and gimbal height. The shapes of the gimbals were dictated by the bearings selected to handle the loads and the 50.0[mm] distance between the bearing axis and the compliant beam neutral axis. The trunnion was shaped to withstand the loads of the actuator while not inhibiting assembly. The trunnion is slightly asymmetric with one arm longer than the others. This design allowed for easy assembly of the joint. Additionally, it could be used in a traditional universal joint to bias the range of motion.

Figure 8 shows the maximum achievable universal joint roll angle for a given pitch angle and gimbal height. The data were generated using a preliminary CAD model by varying the height from the bottom of the roll gimbal to its bearing axis and recording the roll angle at which interference occurs. The final gimbal height of 18mm was chosen for the upper universal joint because it was the minimum length which exceeded the angle requirements of all the universal joints.

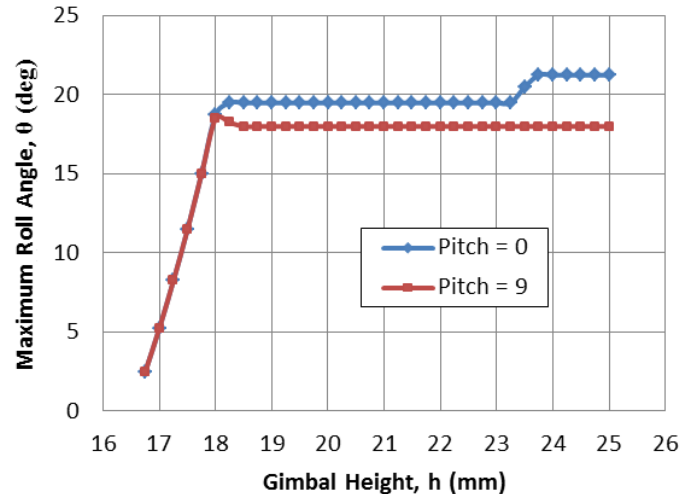

Figure 8: Achievable upper universal joint range of motion for a range of gimbal heights

The same upper universal joint is used to attach the hip yaw/roll and ankle actuators to the compliant spring. Slightly modified versions are used to connect the hip pitch and knee actuators to their respective compliant springs. These joints use a planar four-bar linkage to achieve high ranges of motion with similar linear SEAs [9,17]. Even though the linkage mechanism is planar, an upper universal joint is on the end of both actuators to account for manufacturing errors. The actuators were originally designed with only pin joints at their tops, but testing revealed the need for universal joints. To reduce the number of remanufactured parts, the upper universal joints were redesigned instead of the whole thigh structure.

The hip pitch actuator uses a slightly shorter version of the upper universal joint gimbal than the other hip actuators. This reduces the roll range of motion for that actuator, which is only needed to account for manufacturing and assembly errors. The knee pitch actuator uses a completely different trunnion from the other upper universal joints. In order to reduce the housing length as much as possible, the load cell is integrated into the trunnion, similar to the SAFFiR SEA. Since this universal joint is subjected to negligible roll rotation, bending forces through the load cell are diminished. This trunnion can be seen in Figure 7.

3.2 Lower Hip Universal Joint

The universal joint that connects the hip to the coxa is shaped in an unconventional style. This universal joint has a large range of motion requirement because it is located close to the hip joint [9]. As seen in Table 3, the required roll range of motion for this joint is extremely biased and significantly larger than the needed pitch range of motion. The asymmetry in the joint range of motion was motivation to use a non-traditional trunnion design.

Table 3: Lower hip universal joint range of motion requirements

Universal Joint Location	Min. Roll	Max. Roll	Min. Pitch	Max. Pitch
Front Hip	-61.6	22.5	-17.5	6.1
Back Hip	-67.2	27.0	-10.1	7.5

The roll range of motion would be difficult to achieve with a traditional universal joint design. Additionally, these joints are attached to the outside of the coxa in the middle of the hip joint. It was imperative that the joints did not occupy a large volume so that they would not interfere with the leg over its range of motion. A number of trunnion designs were tested before settling on the hybrid gimbal/trunnion design with a capital “Y” shape. This shape reduced the outward profile of each universal joint while providing a larger region of unimpeded roll motion. The joint attached to the coxa is shown in Figure 8.

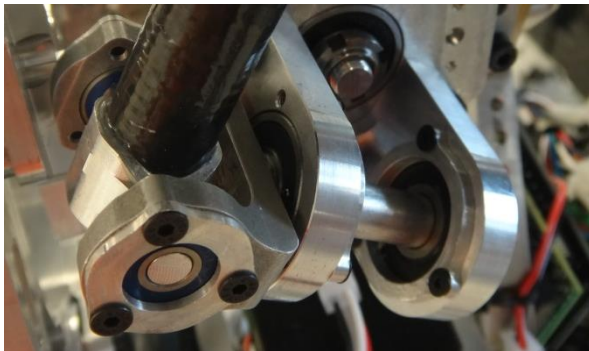

Figure 8: Lower universal joint for the hip actuators

Though this universal joint design allows for the necessary range of motion, it has its detriments. First, one of the axes of the trunnion is placed in single support. This required the use of larger bearings to support the radial loads.

This configuration for the cross gimbal presents a new failure mode not present in traditional universal joints. If the portion of the trunnion in single support would axially align with the axis of the actuator, the actuator would completely lose command authority over the joint. The motor would freely spin as the trunnion rotated in its bearings. This issue forced the universal joint to be angled relative to the transversal plane.

The pitch axis of the joint could not be parallel to the transversal plane due to part interferences, but it needed to approach horizontal while still accommodating the range of motion. This led to a nominal angle of 86.5° between the actuator and cross gimbal, which leaves a 19.2° angle between the ball screw and cross gimbal when the universal joint is at the limit of its range of motion.

3.3 Lower Ankle Universal Joint

The lower ankle universal joint has the largest overall range of motion requirement on THOR. Since it is attached to the foot, the joint needs to be compact and lightweight. Table 4

shows the range of motion requirements for the ankle universal joints. Similar to the upper universal joints, the ankle joints are designed to be symmetric in roll to reduce the number of individual parts to be designed.

Table 4: Lower ankle universal joint range of motion requirements

Universal Joint Location	Min. Roll	Max. Roll	Min. Pitch	Max. Pitch
Ankle	-33.9	35.2	-38.5	54.1

Because it requires a larger range of motion, the pitch axis of the lower ankle universal joint is attached to the foot, while the roll axis is attached to the actuator. This arrangement simplified the design challenge to achieve the full range of motion, as it is possible to lengthen the trunnion to avoid interferences. An image of the lower ankle universal joint can be seen in Figure 9.



Figure 9: Lower universal joint for the ankle actuators

This universal joint was designed to specifically meet the range of motion requirements of the lower ankle universal joint while avoiding part interferences with the shin at the extreme ends of the ankle motion. For example, the universal joint requires 54.1° of pitch motion. The lower ankle universal joint is designed to have 56° of motion before its two ends collide with one another. This design philosophy also reduced the amount of material at the foot, decreasing the overall rotational inertia of the leg.

4. HOEKEN'S LINKAGE ACTUATOR

As stated earlier, the linear SEAs are an integral component of the four-bar mechanisms used to drive the hip and knee pitch joints [9,17]. These mechanisms allow the leg to attain large ranges of motion with nearly constant torque outputs. However, the linkages are too large to realistically fit at all the joints on THOR. An image of the Hoeken's linkage in the knee is shown in Figure 10.

The actuators used in the linkages are nearly identical to the other actuators in the legs. Aside from variations in the upper universal joints that were highlighted in Section 3.1, the main difference is that these actuators exclude the carbon fiber

tubes and lower universal joints. Those parts are replaced with a simple pin joint attached to the ball nut.

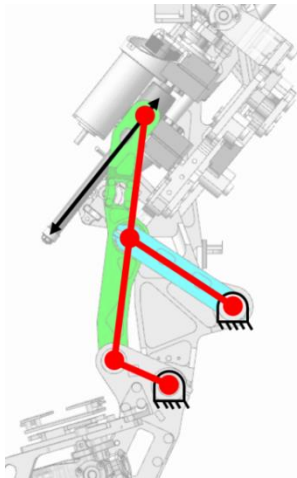

Figure 10: Hoeken's linkage in the knee

This alternate configuration for the THOR linear SEA highlights its versatility. Similar to the other joints, the SEA allows the knee and hip pitch to be force controlled. This linkage produces high torques over the full joint range of motion, which overcomes one of the usual shortcomings of linear actuated systems.

5. CONCLUSIONS

This paper presents the design of the compact, high-force linear SEA for THOR. An evolutionary advancement to the SAFFiR SEA, this SEA has a compact bearing structure that uses less space and accommodates larger forces. The housing is designed to hold alternate pulley ratios to rapidly change the force/speed ratio of any actuator. The housing also places the integrated load cell in-line with the ball screw axis, reducing the bending loads passing through the sensor. The configurable compliant spring is oriented parallel to the actuator, placing it in pure bending when the actuator exerts forces.

The actuators are equipped with custom universal joints that match their necessary ranges of motion. A single upper joint is designed to fit in both the parallel hip and ankle actuators to reduce the number of individual parts. The lower hip universal joints have a non-traditional trunnion to accommodate for a large, biased range of motion. The lower ankle joints are extremely compact to prevent interference with the shin over the ankle range of motion. Two actuators on each leg incorporate a Hoeken's linkage to drive the hip and knee pitch joints through a large range of motion with high torques. This alternate configuration of the actuator highlights the versatility of the SEA design.

There are a number of areas for future investigation with this linear SEA. This paper only covered the design of the key systems in the SEA. These areas for work are currently under investigation by the authors.

- While many good models exist for linear SEAs [7], they lump the translational and rotary inertias into a single inertia, and do not correctly account for the internal dynamics of the actuator. The authors are working on a new model for ball screw-driven linear SEAs which decouples the individual inertias in order to derive a more accurate dynamic model.
- The SEAs move under load because of the configurable compliant spring design. This motion, while not large, impacts the overall range of motion of the joints in THOR. The actuator placement across each joint was done without considering the implications of compliant deflection, so it is necessary to solve for a revised range of motion for the joints to account for this deflection.
- While the actuators are designed to have low amounts of friction, it is still present in the system. These traits are difficult to account for in a theoretical model of the actuator. A friction model or friction observer would allow the controller to compensate, resulting in better control of the actuator.

ACKNOWLEDGMENTS

This work is supported by DARPA through grant N65236-12-1-1002 and by ONR through grant N00014-11-1-0074.

REFERENCES

- [1] Lee, B., Orekhov, V., Lahr, D., and Hong, D., "Design and Measurement Error Analysis of a Low-Friction, Lightweight Linear Series Elastic Actuator." Proceedings of the ASME International Design Engineering Technical Conferences & Computers and Information Engineering Conference, 2013.
- [2] Pratt, G. and Williamson, M., "Series Elastic Actuators". Proceedings of the IEEE International Conference on Intelligent Robots and Systems, Vol. 1, pp. 399-406, 1995.
- [3] Pratt, J. and Krupp, B., "Series Elastic Actuators for Legged Robots". Proceedings of SPIE Unmanned Ground Vehicle Technology VI, Vol. 5422, pp. 135-144, 2004.
- [4] Pratt, J., Krupp, B., and Morse, C., "Series Elastic Actuators for High Fidelity Force Control". Industrial Robot: an International Journal, Vol. 29, No. 3, pp. 234-241, 2002.
- [5] Robinson, D., Pratt, J., Paluska, D., and Pratt, G., "Series Elastic Actuator Development for a Biomimetic Walking Robot". Proceedings of the IEEE/ASME International Conference on Advanced Intelligent Mechatronics, pp. 561-568, 1999.
- [6] Paluska, D., and Herr, H., "The Effect of Series Elasticity on Actuator Power and Work Output: Implications for Robotic and Prosthetic Joint Design". Robotics and Autonomous Systems, Vol. 54, pp. 667-673, 2006.
- [7] Paine, N., Oh, S., and Sentis, L., "Design and Control Considerations for High-Performance Series Elastic Actuators". IEEE/ASME Transactions on Mechatronics, Vol. PP, Iss. 99, pp. 1-12, 2013.

- [8] Lahr, D., Orekhov, V., Lee, B., and Hong, D., "Development of a Parallely Actuated Humanoid, SAFFiR". Proceedings of the ASME International Design Engineering Technical Conferences & Computers and Information in Engineering Conference, 2013.
- [9] Lee, B., Knabe, C., Orekhov, V., and Hong, D., "Design of a Human-Like Range of Motion Hip Joint for Humanoid Robots". Proceedings of the ASME International Design Engineering Technical Conferences & Computers and Information in Engineering Conference, 2014
- [10] Pratt, G., "Low Impedance Walking Robots". Integrative and Comparative Biology, Vol. 42, Iss. 1, pp. 174-181, 2002.
- [11] Pratt, J., and Krupp, B., "Design of a Bipedal Walking Robot". Proceedings of SPIE Unmanned Systems Technology X, Vol. 6962, 2008.
- [12] Hollander, K., and Sugar, T., "Design of Lead Screw Actuators for Wearable Robotic Applications". Proceedings of the ASME International Design Engineering Technical Conferences & Computers and Information in Engineering Conference, Vol. 7, pp. 237-246, 2005.
- [13] Hollander, K., Ilg, R., Sugar, T., and Herring, D., "An Efficient Robotic Tendon for Gait Assistance". ASME Journal of Biomechanical Engineering, Vol. 128, pp. 788-791, 2006.
- [14] Orekhov, V., Lahr, D., Lee, B., and Hong, D., "Configurable Compliance for Series Elastic Actuators". Proceedings of the ASME International Design Engineering Technical Conferences & Computers and Information in Engineering Conference, 2013.
- [15] Van Ham, R., Sugar, T., Vanderborght, B., Hollander, K., and Lefeber, D., "Compliant Actuator Designs". IEEE Robotics and Automation magazine, pp. 81-94, Sep. 2009.
- [16] Hurst, J., Chestnutt, J., and Rizzi, A., "The Actuator With Mechanically Adjustable Series Compliance". IEEE Transactions on Robotics, Vol. 26, No. 4, pp. 597-606, 2010.
- [17] Knabe, C., Lee, B., and Hong, D., "An Inverted Straight Line Mechanism for Augmenting Joint Range of Motion in a Humanoid Robot". Proceedings of the ASME International Design Engineering Technical Conferences & Computers and Information in Engineering Conference, 2014.